

## XGT™ Vortex Grit Removal System

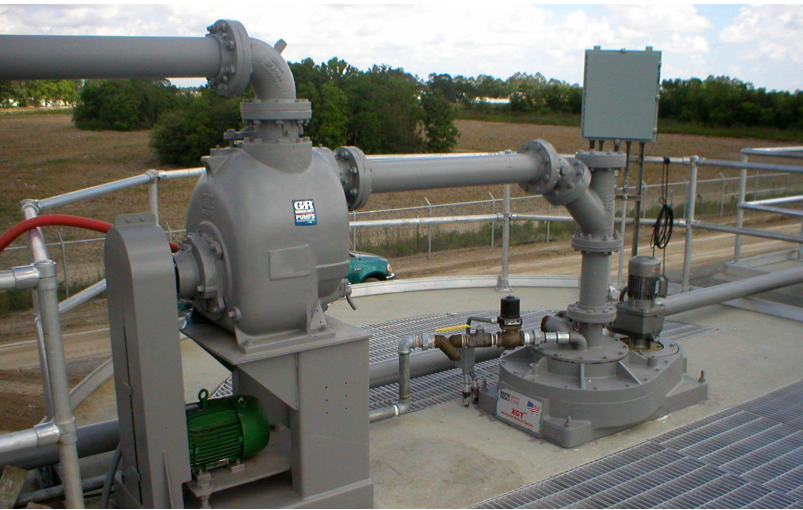

The XGT™ Vortex Grit Removal System has an easy to maintain compact design. This highly efficient design produces cleaner grit with considerably lower organic content.

### OVERVIEW

Kusters Water has been directly involved in the design, manufacture, supply, start up and testing of the XGT™ vortex grit removal technology since 1984. Based on experience with many installations, we have introduced a number of significant improvements to the system. These include the sloping floor design, self-priming grit pump, grit washer and X-impeller. The XGT™ vortex grit system is designed to efficiently remove both fecal and vegetable matter (corn, rice, beans, peas etc.) from the grit in the grit chamber resulting in cleaner grit with considerably lower organic content.

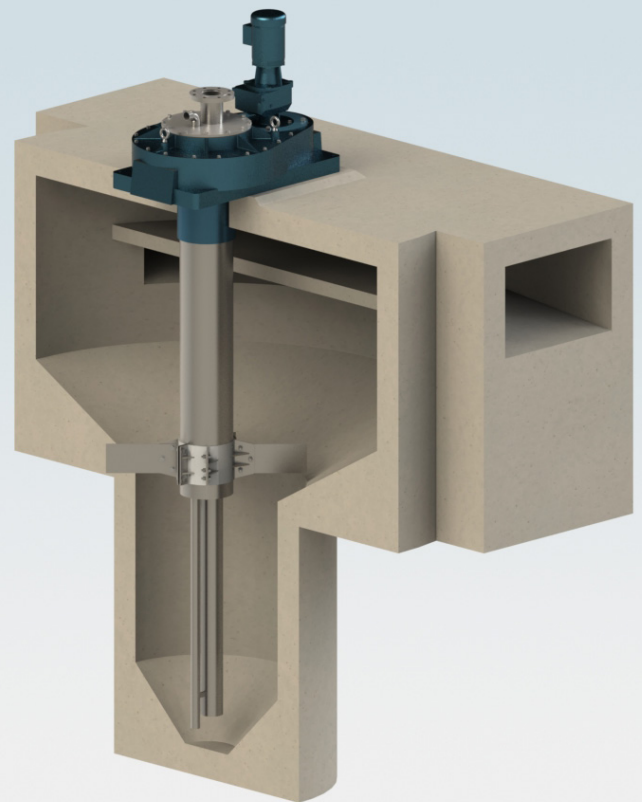

### Features of XGT™

- Low cost and low energy usage
- Sloping floor design
- High efficiency - takes full advantage of gravitational settlement
- Simple, slow rotating X-impeller (1-15 rpm)
- Low headloss design
- Configurations available - 270° or 360°
- Cast iron gearhead
- Air / Water Scouring

## PRINCIPLE OF OPERATION

Wastewater enters the XGT™ grit chamber through the inlet channel and flows along the critical path around the outside of the trap. The lower paddle speeds and minimized velocities achieved in the XGT™ promote optimum grit removal and rejecting of organic materials. Grit separates by gravity in the upper grit chamber and subsequently falls into the lower storage chamber of the trap, while organic material remains in suspension and exits the system. The trapped grit accumulates in the lower grit chamber and is periodically removed via a pump and sent to a grit classifier or grit washer for further dewatering prior to disposal.

## Options for XGT™

- Submersible gearhead
- Explosion proof design
- 304 or 316 SS construction
- Flooded suction pump
- Self priming pump
- Flat floor design
- Steel tank construction
- Airlift pump
- Grit washing



Optional steel tank design



High efficiency X-impeller



Submersible gear head



For more information:

 864.576.0660

 [info@kusterswater.com](mailto:info@kusterswater.com)

 [KustersWater.com](http://KustersWater.com)

KUSTERS WATER DIVISION

 zima  
Jagenberg Group